

ZAF-050 SYSTEM

Field-applied min. 19.1mm deep injected sealant band and corner bead along side
(both sides)

Part Number ZAX0201

- Factory-applied and cured silicone facing available in 26 standard colors (both sides)
- Fire retardant impregnated foam

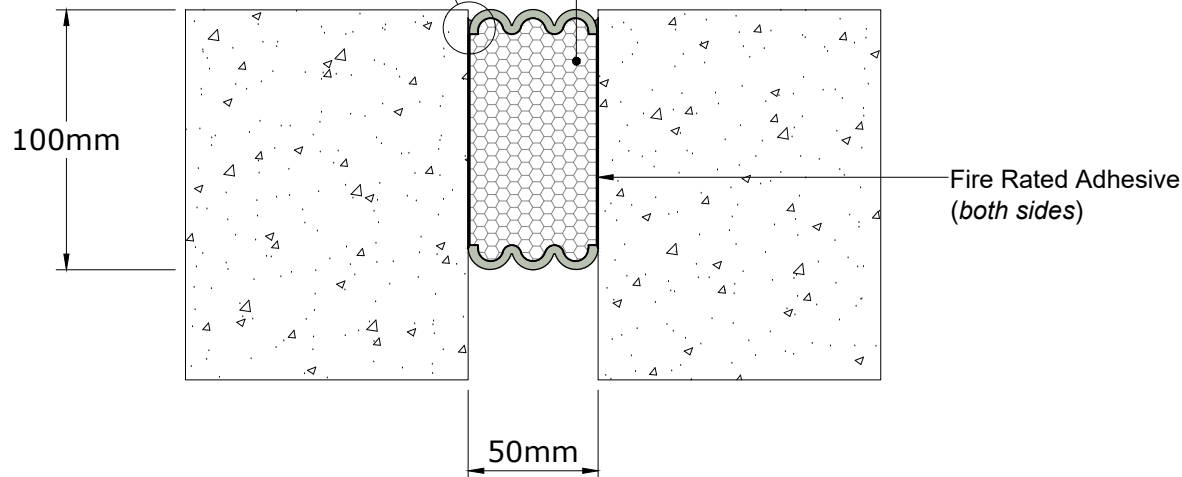

Fire Rated Adhesive
(both sides)

Technical Data

Joint Width	50mm
Movement (Expansion)	50%
Movement (Contraction)	50%
Movement (Shear)	Excellent
Load	*

Date: 06-05-2026	Scale: NTS
Rev: 00	Drawn by: JOE

Application:
**Expansion Joint Cover Fire Barrier
Floor/Wall Condition**



PROSPEC SPECIALTIES INC.
100-1075 North Service Rd. W,
Oakville On L6M2G2,
Canada
Tel : (888) - 749 - 8456
Email: info@prospecspecialties.com
Web : prospecspecialties.com

Disclaimer: As Prospec Specialties' Policy is one of continual technical progress for the improvement of the company's services to its customers, the company reserves the right to modify the Designs of its products without notice.

ZAF-075 SYSTEM

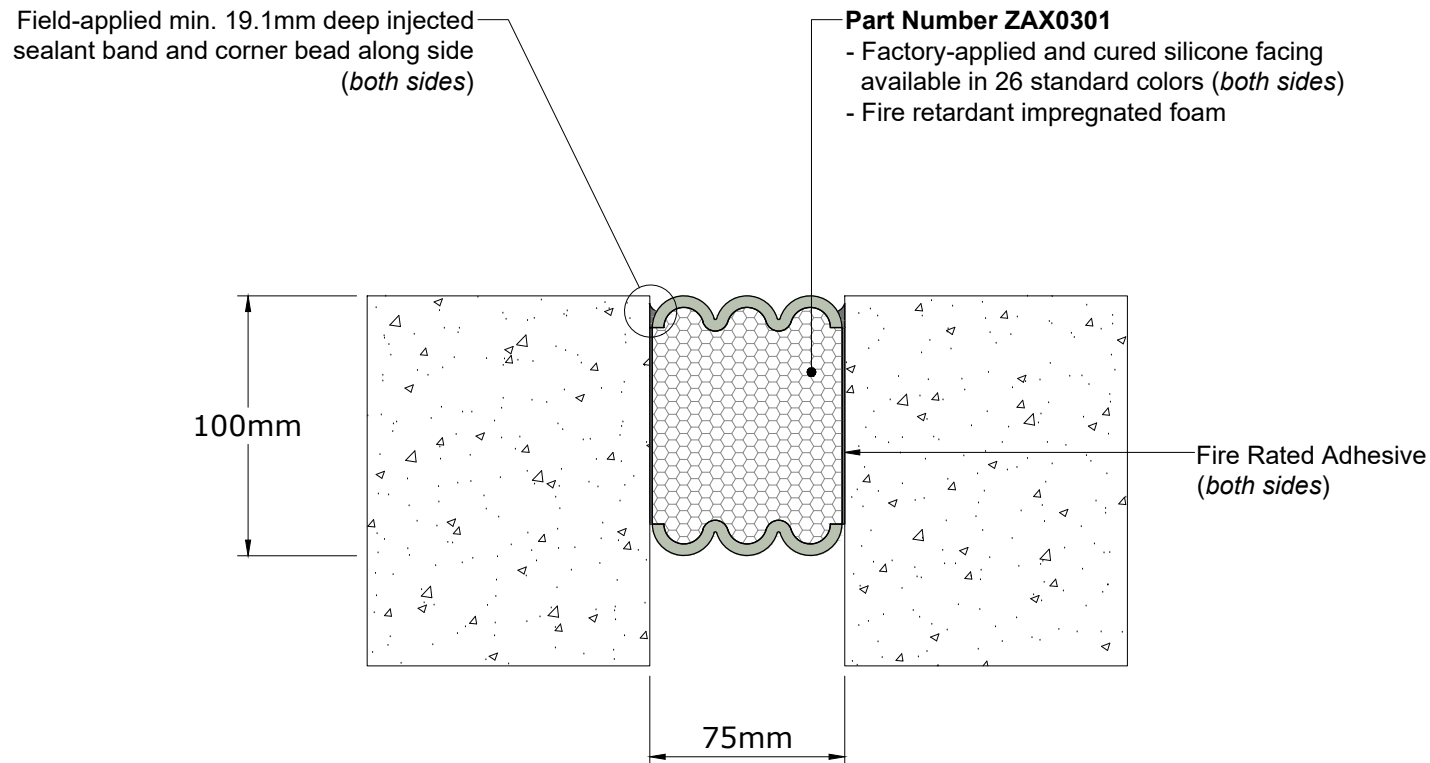

Technical Data

Joint Width	75mm
Movement (<i>Expansion</i>)	50%
Movement (<i>Contraction</i>)	50%
Movement (<i>Shear</i>)	Excellent
Load	*

Date: 06-05-2026	Scale: NTS
Rev: 00	Drawn by: JOE

Application:
**Expansion Joint Cover Fire Barrier
 Floor/Wall Condition**



PROSPEC SPECIALTIES INC.
 100-1075 North Service Rd. W,
 Oakville On L6M2G2,
 Canada
 Tel : (888) - 749 - 8456
 Email: info@prospecspecialties.com
 Web : prospecspecialties.com

Disclaimer: As Prospec Specialties' Policy is one of continual technical progress for the improvement of the company's services to its customers, the company reserves the right to modify the Designs of its products without notice.

ZAF-100 SYSTEM

Field-applied min. 19.1mm deep injected sealant band and corner bead along side *(both sides)*

Part Number ZAX0401

- Factory-applied and cured silicone facing available in 26 standard colors *(both sides)*
- Fire retardant impregnated foam

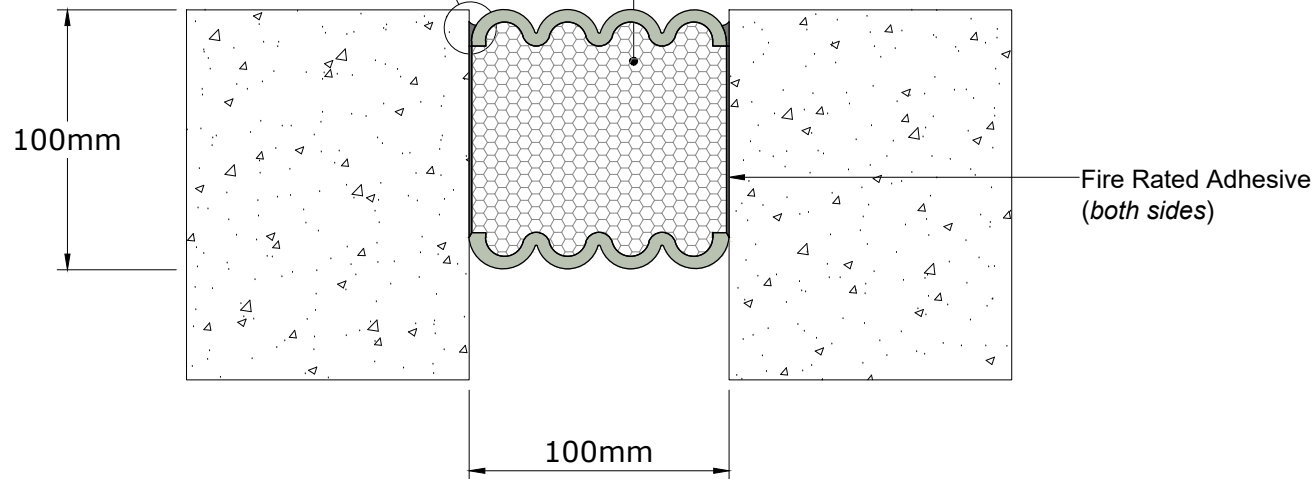

Technical Data

Joint Width	100mm
Movement (<i>Expansion</i>)	50%
Movement (<i>Contraction</i>)	50%
Movement (<i>Shear</i>)	Excellent
Load	*

Date: 06-05-2026	Scale: NTS
Rev: 00	Drawn by: JOE

Application:
**Expansion Joint Cover Fire Barrier
 Floor/Wall Condition**



PROSPEC SPECIALTIES INC.
 100-1075 North Service Rd. W,
 Oakville On L6M2G2,
 Canada
 Tel : (888) - 749 - 8456
 Email: info@prospecspecialties.com
 Web : prospecspecialties.com

Disclaimer: As Prospec Specialties' Policy is one of continual technical progress for the improvement of the company's services to its customers, the company reserves the right to modify the Designs of its products without notice.

ZAF-125 SYSTEM

Field-applied min. 19.1mm deep injected sealant band and corner bead along side (both sides)

Part Number ZAX0501

- Factory-applied and cured silicone facing available in 26 standard colors (both sides)
- Fire retardant impregnated foam

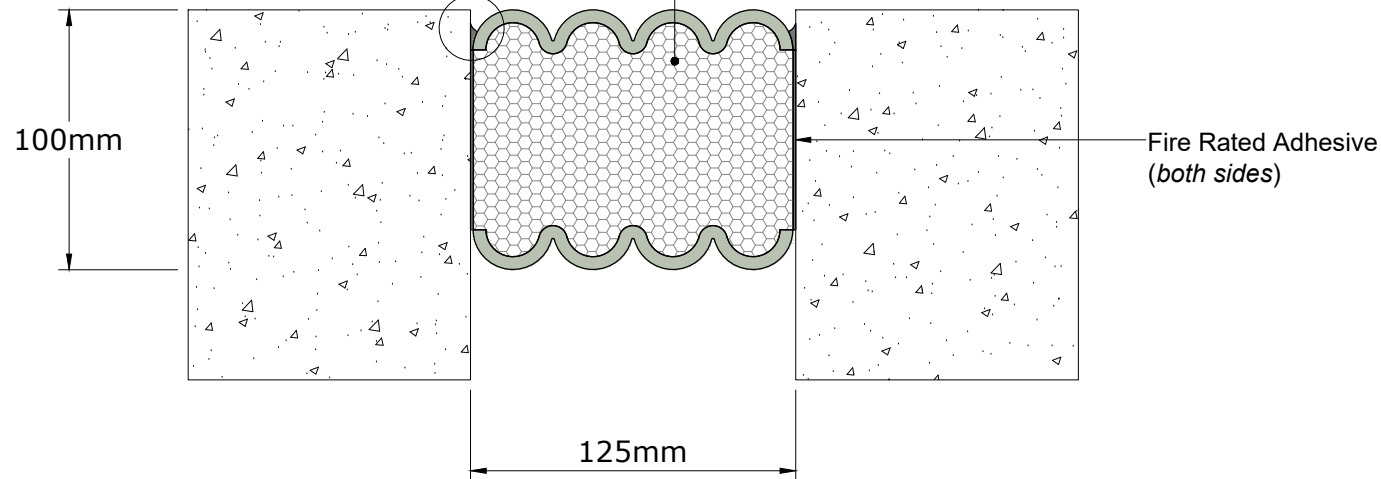

Technical Data

Joint Width	125mm
Movement (Expansion)	50%
Movement (Contraction)	50%
Movement (Shear)	Excellent
Load	*

Date: 06-05-2026	Scale: NTS
Rev: 00	Drawn by: JOE

Application:
**Expansion Joint Cover Fire Barrier
 Floor/Wall Condition**



PROSPEC SPECIALTIES INC.
 100-1075 North Service Rd. W,
 Oakville On L6M2G2,
 Canada
 Tel : (888) - 749 - 8456
 Email: info@prospecspecialties.com
 Web : prospecspecialties.com

Disclaimer: As Prospec Specialties' Policy is one of continual technical progress for the improvement of the company's services to its customers, the company reserves the right to modify the Designs of its products without notice.

ZAF-150 SYSTEM

Field-applied min. 19.1mm deep injected sealant band and corner bead along side (both sides)

Part Number ZAX0601

- Factory-applied and cured silicone facing available in 26 standard colors (both sides)
- Fire retardant impregnated foam

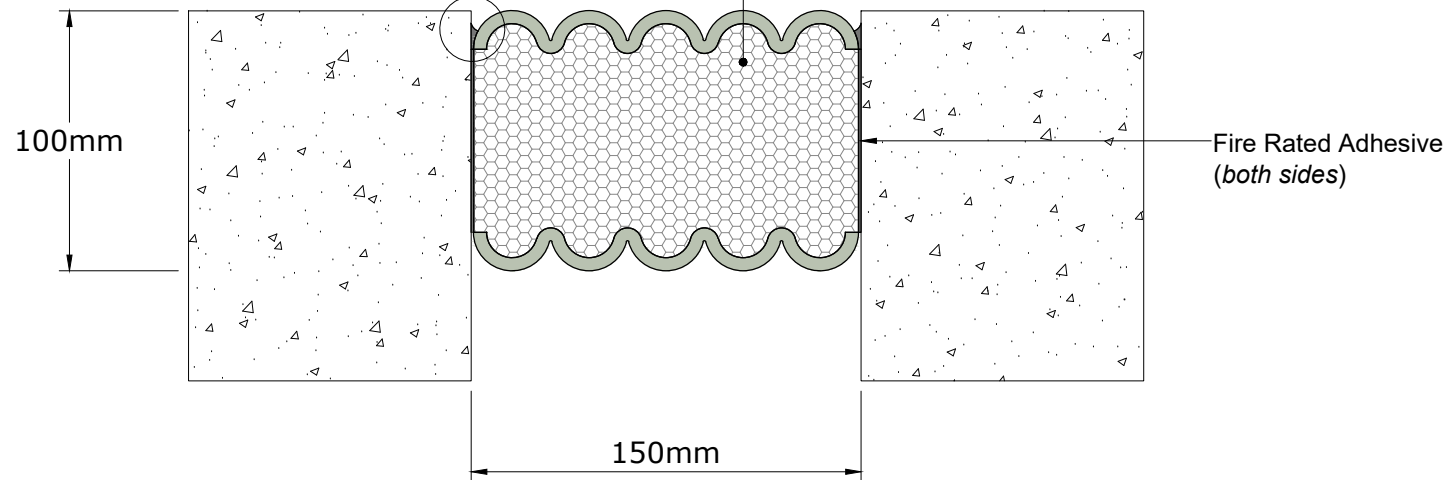

Technical Data

Joint Width	150mm
Movement (Expansion)	50%
Movement (Contraction)	50%
Movement (Shear)	Excellent
Load	*

Date: 06-05-2026	Scale: NTS
Rev: 00	Drawn by: JOE

Application:
**Expansion Joint Cover Fire Barrier
 Floor/Wall Condition**



PROSPEC SPECIALTIES INC.
 100-1075 North Service Rd. W,
 Oakville On L6M2G2,
 Canada
 Tel : (888) - 749 - 8456
 Email: info@prospecspecialties.com
 Web : prospecspecialties.com

Disclaimer: As Prospec Specialties' Policy is one of continual technical progress for the improvement of the company's services to its customers, the company reserves the right to modify the Designs of its products without notice.