

HDS025 SYSTEM

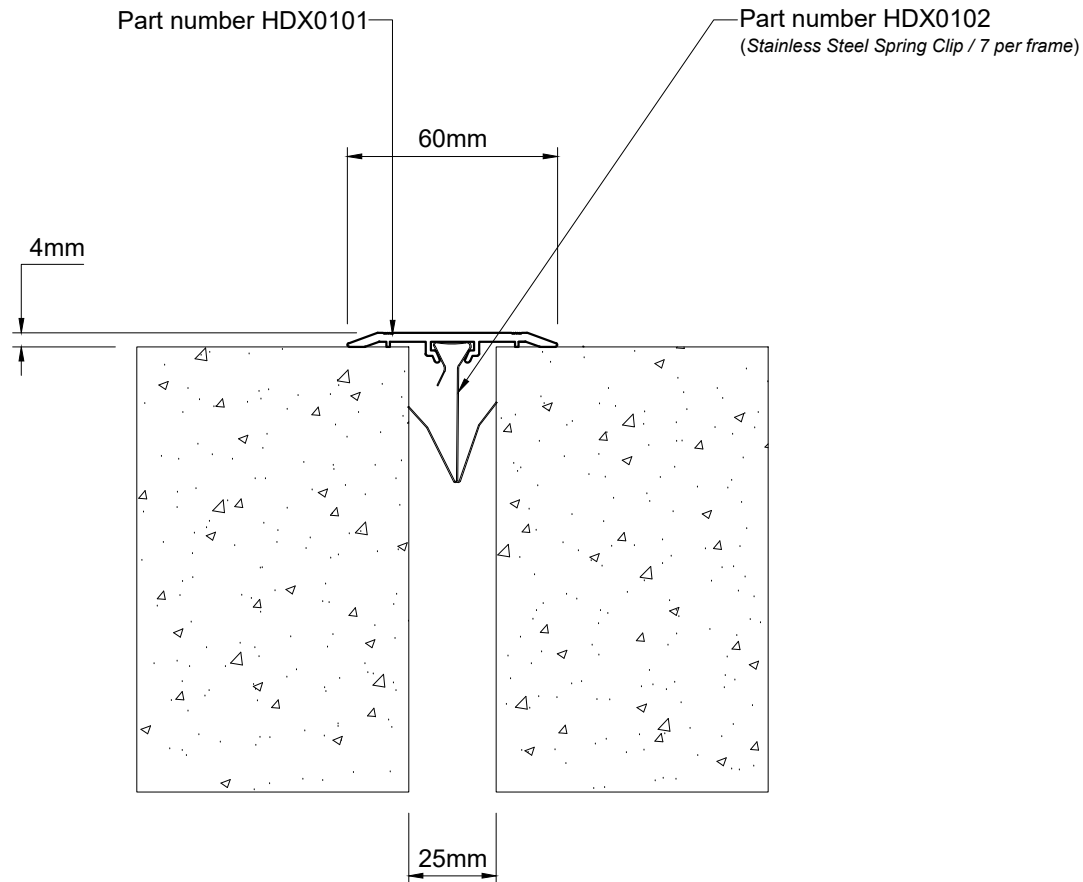

Technical Data

Joint Width	25mm
Movement (<i>Expansion</i>)	50%
Movement (<i>Contraction</i>)	50%
Movement (<i>Shear</i>)	Excellent
Load	

Date:	Scale: NTS
Rev:	Drawn by:

Application:

Expansion Joint Cover for Wall to Wall Condition



PROSPEC SPECIALTIES INC.

26-5250 Satellite Drive,
Mississauga, Ontario L4W 5G5,
Canada

Tel : (888) - 749 - 8465
Email: info@prospecspecialties.com
Web : prospecspecialties.com

Disclaimer: As Prospec Specialties' Policy is one of continual technical progress for the improvement of the company's services to its customers, the company reserves the right to modify the Designs of its products without notice.

HDS050 SYSTEM

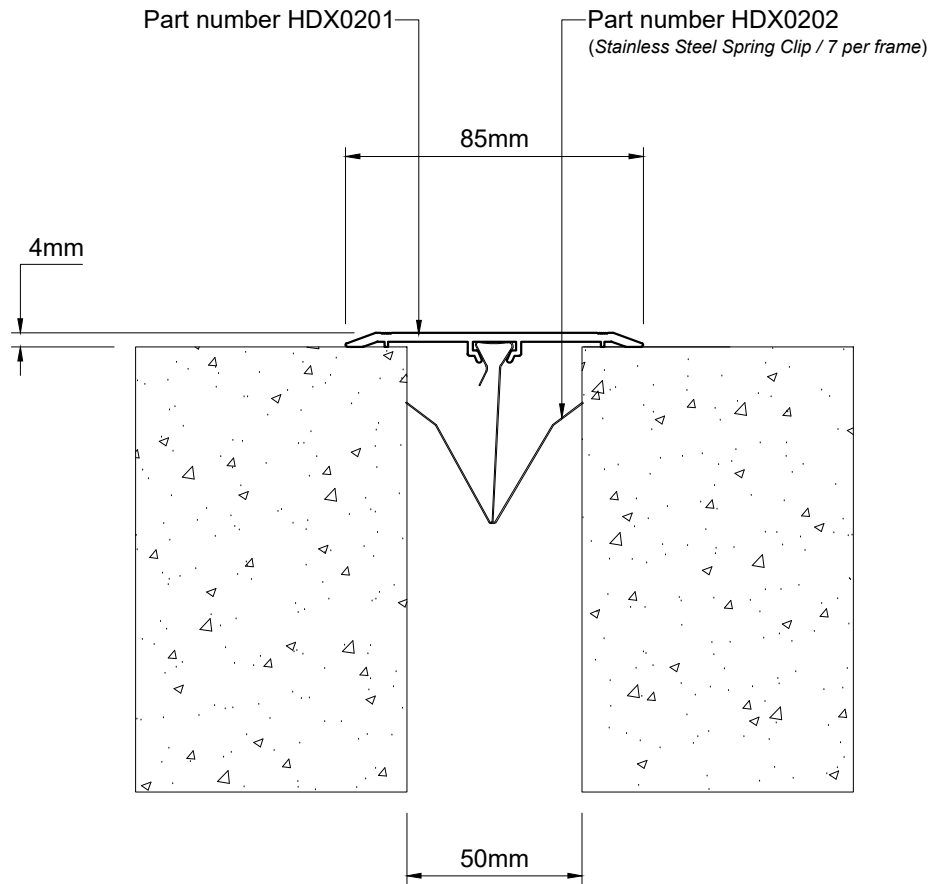

Technical Data

Joint Width	50mm
Movement (<i>Expansion</i>)	50%
Movement (<i>Contraction</i>)	50%
Movement (<i>Shear</i>)	Excellent
Load	

Date: Scale: NTS

Rev: Drawn by:

Application:

Expansion Joint Cover for Wall to Wall Condition



PROSPEC SPECIALTIES INC.

26-5250 Satellite Drive,
Mississauga, Ontario L4W 5G5,
Canada

Tel : (888) - 749 - 8465

Email: info@prospecspecialties.com

Web : prospecspecialties.com

Disclaimer: As Prospec Specialties' Policy is one of continual technical progress for the improvement of the company's services to its customers, the company reserves the right to modify the Designs of its products without notice.

HDS075 SYSTEM

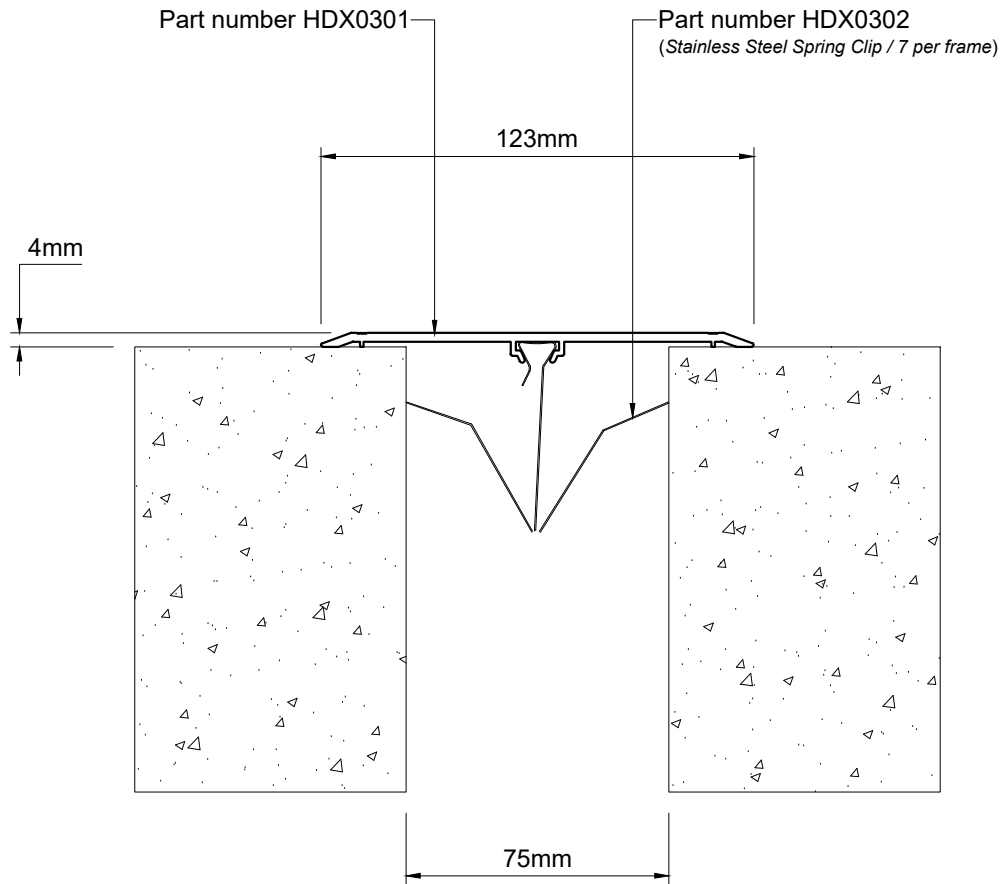

Technical Data

Joint Width	75mm
Movement (<i>Expansion</i>)	50%
Movement (<i>Contraction</i>)	50%
Movement (<i>Shear</i>)	Excellent
Load	

Date: Scale: NTS

Rev: Drawn by:

Application:

Expansion Joint Cover for Wall to Wall Condition



PROSPEC SPECIALTIES INC.

26-5250 Satellite Drive,
Mississauga, Ontario L4W 5G5,
Canada

Tel : (888) - 749 - 8465

Email: info@prospecspecialties.com

Web : prospecspecialties.com

Disclaimer: As Prospec Specialties' Policy is one of continual technical progress for the improvement of the company's services to its customers, the company reserves the right to modify the Designs of its products without notice.

HDS100 SYSTEM

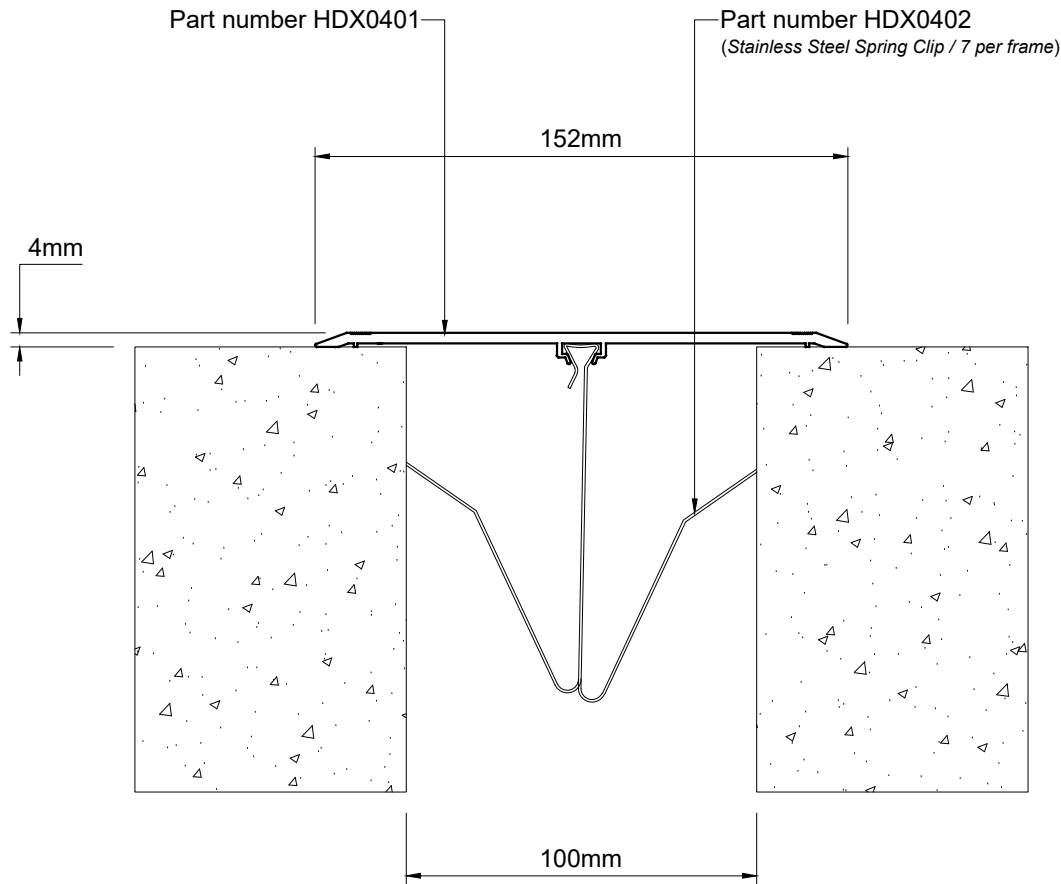

Technical Data

Joint Width	100mm
Movement (<i>Expansion</i>)	50%
Movement (<i>Contraction</i>)	50%
Movement (<i>Shear</i>)	Excellent
Load	

Date: Scale: NTS

Rev: Drawn by:

Application:

Expansion Joint Cover for Wall to Wall Condition



PROSPEC SPECIALTIES INC.

26-5250 Satellite Drive,
Mississauga, Ontario L4W 5G5,
Canada

Tel : (888) - 749 - 8465

Email: info@prospecspecialties.com

Web : prospecspecialties.com

Disclaimer: As Prospec Specialties' Policy is one of continual technical progress for the improvement of the company's services to its customers, the company reserves the right to modify the Designs of its products without notice.

HDS150 SYSTEM

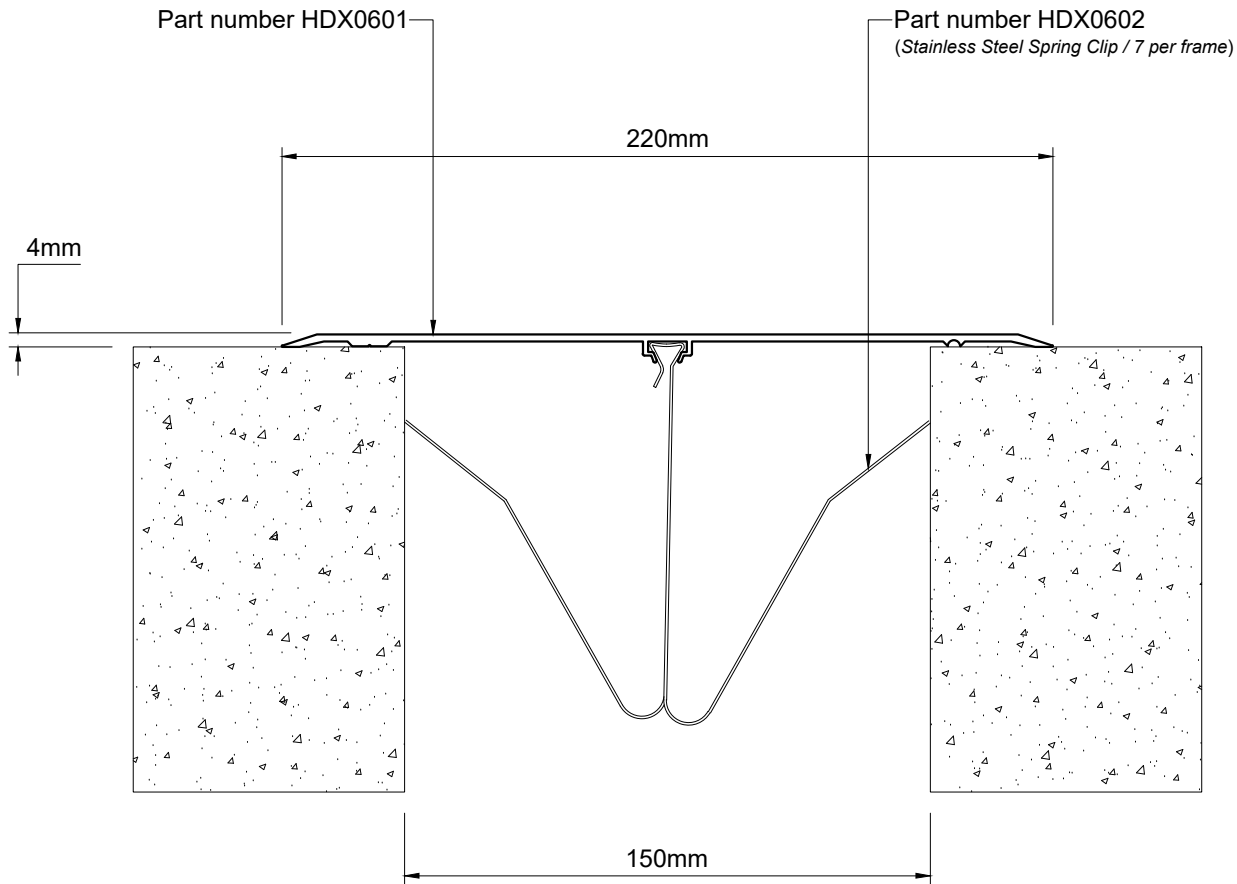

Technical Data

Joint Width	150mm
Movement (<i>Expansion</i>)	50%
Movement (<i>Contraction</i>)	50%
Movement (<i>Shear</i>)	Excellent
Load	

Date: Scale: NTS

Rev: Drawn by:

Application:

Expansion Joint Cover for Wall to Wall Condition



PROSPEC SPECIALTIES INC.

26-5250 Satellite Drive,
Mississauga, Ontario L4W 5G5,
Canada

Tel : (888) - 749 - 8465

Email: info@prospecspecialties.com

Web : prospecspecialties.com

Disclaimer: As Prospec Specialties' Policy is one of continual technical progress for the improvement of the company's services to its customers, the company reserves the right to modify the Designs of its products without notice.

HDS200 SYSTEM

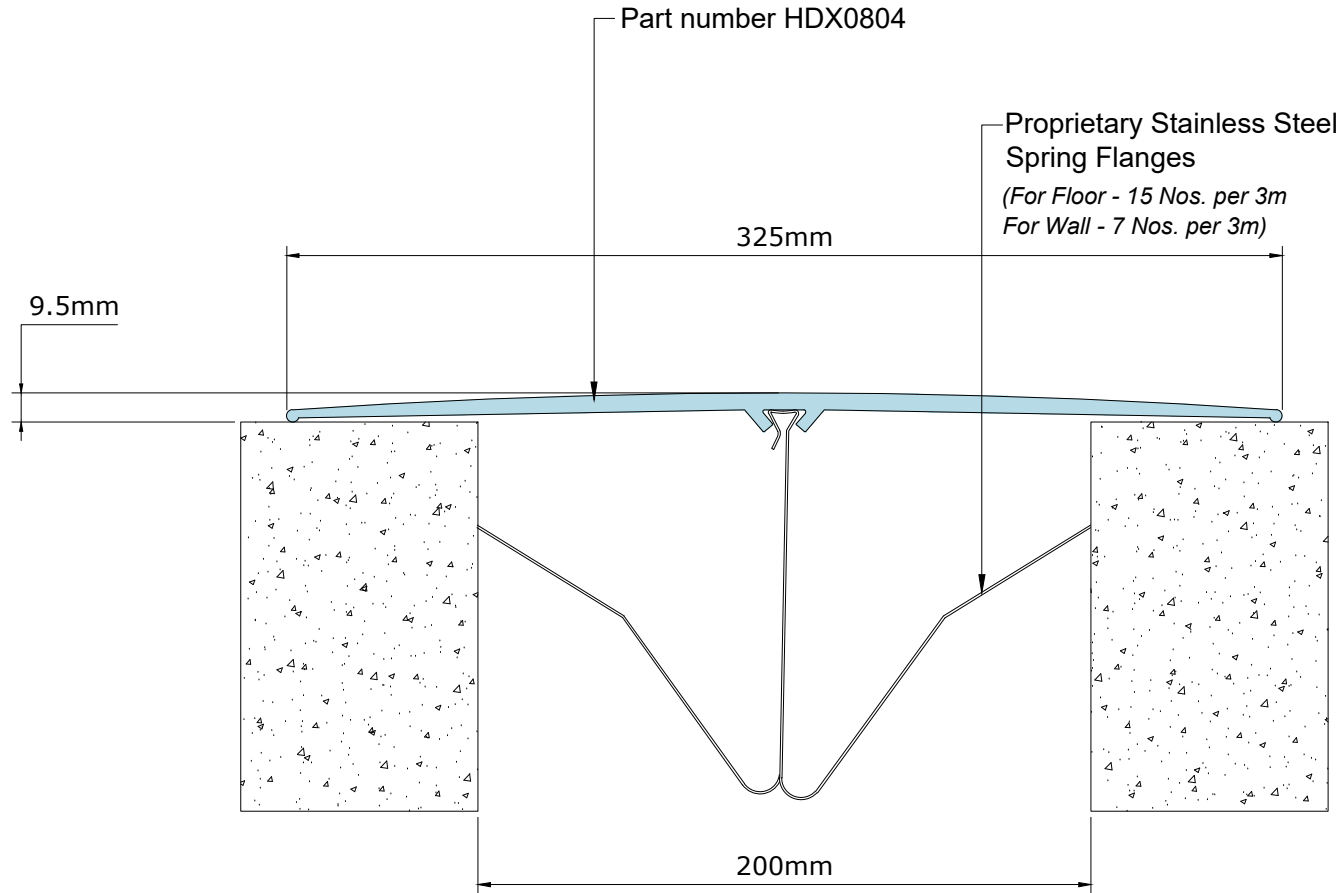

Technical Data

Joint Width	200mm
Movement (<i>Expansion</i>)	50%
Movement (<i>Contraction</i>)	50%
Movement (<i>Shear</i>)	Excellent
Load	1.5 Tons

Date: 09-02-2026	Scale: NTS
Rev: 00	Drawn by: AV

Application:
Expansion Joint Cover for Floor to Floor/
Wall to Wall Condition



PROSPEC SPECIALTIES INC.

100-1075 North Service Rd. W,
Oakville On L6M2G2,
Canada

Tel : (888) - 749 - 8456
Email: info@prospecspecialties.com
Web : prospecspecialties.com

Disclaimer: As Prospec Specialties' Policy is one of continual technical progress for the improvement of the company's services to its customers, the company reserves the right to modify the Designs of its products without notice.